

SURGE PROTECTIVE DEVICE (SPD)
 WEIGHTS & DIMENSIONS
 NEMA RATING: 4X NON METALLIC

REV	EG	CHANGED	DATE	APPROVED

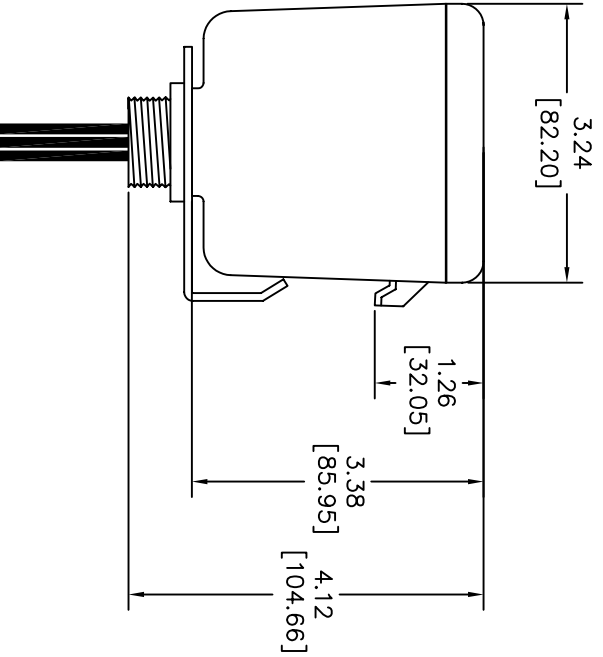
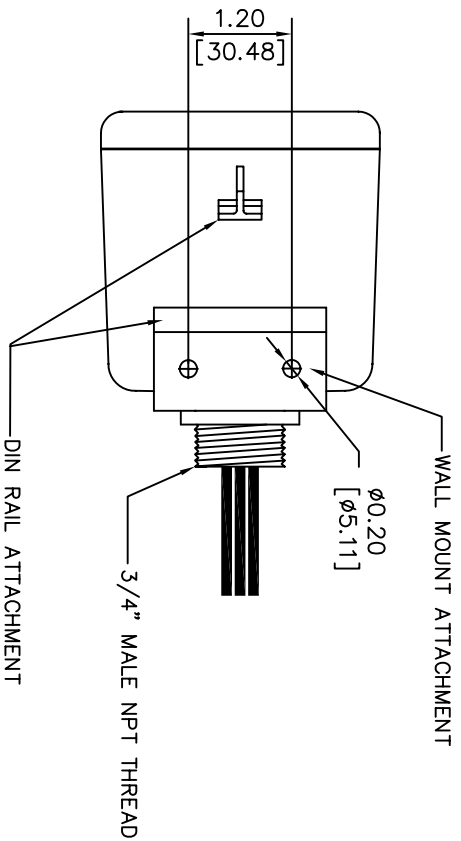
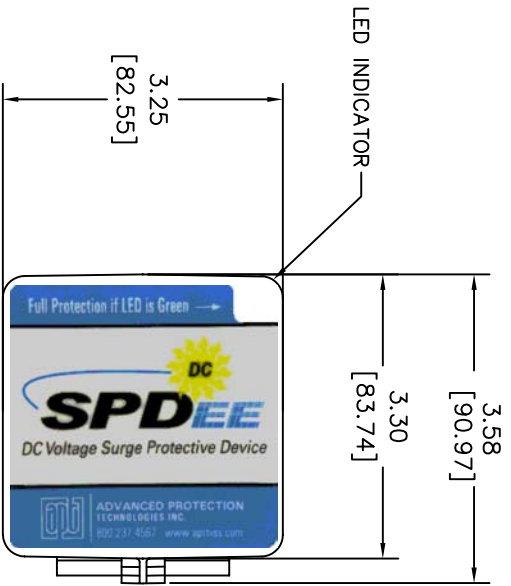

ENCLOSURE SPECS.:
 DESC: NON-METALLIC ENCLOSURE
 DIM: 3.30"H x 3.25"W x 3.38"D
 MAT: POLYCARBONATE (V2 & F1)
 FINISH: GRAY
 NEMA RATING: 4X
 DEVICE WEIGHT: 1.6LBS. (0.72 KG.)

EXTERNAL SPECS. IS UNCONTROLLED WHEN PRINTED.
 ALWAYS VERIFY LABELS' REVISIONS IN USE.

MATERIAL: POLYCARBONATE (V2, F1)

SPECIFICATION:

FINISH:

PRODUCT:

ITEM CODE:

DATE:

BY:

DESIGNED BY:

APPROVED BY:

DATE:

BY:

DESIGNED BY:

APPROVED BY:

DATE:

BY:

ADVANCED PROTECTION TECHNOLOGIES
 DELANDER, FL, USA 34420

SPD_{EE} DC SERIES
 NEMA: 4X

43D-SPD_{EE}-DC-4XM

SHEET 1 OF 1