



TE/XGA Series & XTE/XGA Series

Surge Protective Device (SPD)

Installation, Operation & Maintenance Manual



Advanced Protection Technologies
14550 58th St. N.
Clearwater, FL 33760

(800) 237-4567, (727) 535-6339
Fax (727) 539-8955

www.aptspd.com

TRANSIENT  ELIMINATOR[®]



WARNING – IMPORTANT – PLEASE READ – WARNING

Safety First – Hazardous Voltage & Shock Hazard

- Only qualified licensed electricians should install or service SPDs
- Hazardous voltages exist within SPDs
- SPDs should never be installed or serviced when energized
- Use appropriate safety precautions including Personal Protection Equipment
- Failure to follow these instructions can result in death, serious injury, and/or equipment damage.
- This manual shall be read in entirety prior to installing

Bonding and Grounding Hazard

Verify that the neutral conductor in the service entrance equipment is bonded to ground in accordance with the National Electric Code (NEC®) and all applicable codes.

Verify that the neutral terminal (XO) on the secondary side of distribution transformers are grounded to the system ground in accordance with the NEC® and all applicable codes.

During installation into an electrical system the SPD must not be energized until the electrical system is completely installed, inspected and tested. All conductors must be connected and functional including the neutral (if required). The voltage rating of the SPD and system must be verified before energizing the SPD.

Failure to follow these guidelines can lead to abnormally high voltages at the SPD. This may cause the SPD to fail. The warranty is voided if the SPD is incorrectly installed and/or if the neutral conductor in the service entrance equipment or downstream of separately derived systems is not bonded to ground in accordance with the NEC®.

Do Not Hi-Pot Test SPDs

Any factory or on-site testing of power distribution equipment that exceeds normal operating voltage such as high-potential insulation testing, or any other tests where the suppression components will be subjected to higher voltage than their rated Maximum Continuous Operating Voltage (MCOV) must be conducted with the SPD disconnected from the power source. For 4-wire systems, the neutral connection at the SPD must also be disconnected prior to performing high-potential testing and then reconnected after test completion.

Failure to disconnect SPD and associated components during elevated voltage testing will damage the SPD and will void the warranty.

TABLE OF CONTENTS

INTRODUCTION	1
Major Industry Nomenclature Changes Effective 2008-2009.....	1
Simplified Explanation of Operation.....	1
Parallel Connection.....	1
Precautionary Statement Regarding SPDs on Ungrounded Systems	1
Unpacking & Preliminary Inspection	1
Storage Environment	2
PRE-INSTALLATION & PLANNING	2
Operating Environment.....	2
Audible Noise	2
Mounting, Dimensions, and Weight	2
Service Clearance.....	2
Maximizing SPD Performance	2
Cascade Surge Protection	2
Overcurrent Protection.....	2
Circuit Breaker and Disconnect Switch.....	2
Wire Size and Installation Torque.....	2
Shortest Leads Possible	3
Special Enclosure Considerations	3
Removing and Reconnecting the Ribbon Cables	3
NEMA Type 4X Enclosure.....	3
Flush Mount Option.....	3
Terminals.....	3
Configuration Management & Part Numbering System	4
Voltage Rating.....	4
System Grounding	4
UL 1283 required language concerning the installation of EMI Filters	5
INSTALLATION	7
Common Problems to Avoid.....	7
Pre-Plan your installation.	7
Electrical Connection Diagrams.....	8
Surge Counter Options	9
OPERATION.....	9
Supplemental LED indicators on Modules	10
Dry Contact Option.....	10
MAINTENANCE	11
Module Removal and Replacement.....	11
Display/Diagnostic Board Removal and Replacement.....	11
Preventive Maintenance (Inspection and Cleaning)	12
Corrective Maintenance (Repair)	12
Limited Warranty	12

FIGURES

2008 NEC Art 285 & UL 1449-3	1
Flush Mount front view.....	3
Flush Mount Side View	3
NEMA Type 1, 4, and 4X Stainless Steel	6
NEMA Type 3R.....	6
NEMA Type 4X Plastic	6
Typical Panel Installation.....	7
Module LED	10
Pinout Diagram for Dry Contacts of SPD	10
Trouble Shooting Flowchart	11

TABLES

Table 1: Voltage Rating and Service Type	4
Table 2: Model Number Decoder	5
Table 3: Replacement Parts.....	12

INTRODUCTION

Thank you for choosing an APT Surge Protective Device (SPD). This is a high quality, high energy surge suppressor designed to protect sensitive equipment from damaging transient overvoltages.

Proper installation is important to maximize performance. Please follow steps outlined herein.

This entire Operation & Maintenance Manual should be read prior to beginning installation. These instructions are not intended to replace national or local codes. Follow all applicable electrical codes to ensure compliance. Installation of this SPD should only be performed by qualified electrical personnel.

APT SPDs are extensively tested in accordance with industry standards such as ANSI/IEEE C62.41.1, C62.41.2, C62.45, C62.62, C62.72, UL 1449, UL 1283, IEC 61643, etc.

This SPD is a single-port parallel-connected device intended for service entrance, panelboard or downstream installation for IEEE Category C, B or A applications

Major Industry Nomenclature Changes Effective 2008-2009

Be aware that UL 1449 Third Edition and 2008 NEC® Article 285 generated substantial changes.

- The term TVSS changed to SPD
- Types 1, 2, 3 & 4 SPDs are created
- UL 1449 clamping voltage performance testing changed from 500A to 3,000A
- UL 1449 added new I nominal testing (In), which consists of more rigorous duty-cycle testing

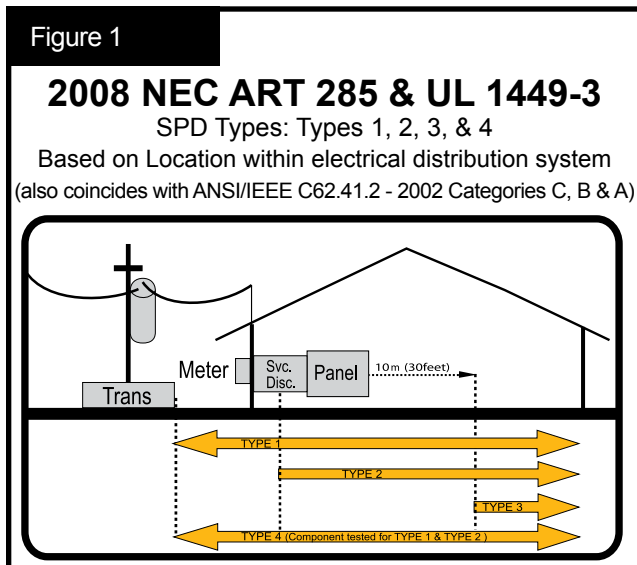

This SPD complies with the latest regulatory actions and is UL Listed as such.

For further information, please review latest editions of NEC® Art. 285, UL 1449 or contact APT Tech Support at (800) 237-4567

GENERAL INFORMATION

This is a Type 2 SPD. It includes internal overcurrent protection. Type 2 SPDs are suitable for installation on the load side of the service disconnect overcurrent device.

This device features internal overcurrent and overtemperature protection that will disconnect effected surge suppression components at the end of their useful life, but will maintain power to the load – now unprotected. If this situation is undesirable for the application, follow these instructions for servicing or replacing the device.

Service of this unit consists of replacing internal modules and/or display assembly.

There are no user-serviceable parts inside the replaceable modules. Do not attempt to disassemble the module as it stores charge and is potted.

Simplified Explanation of Operation

SPDs sense overvoltage and create a momentary short circuit to redirect harmful surge energy to earth ground. Then they reset automatically and wait for the next surge. This is similar to the pressure relief valve on a water heater: pressure goes up, valve opens to relieve pressure and then resets. In an electrical system, an SPD senses overvoltage, shorts temporarily sending energy to ground and then resets. SPDs are capable of repeating this function thousands of times.

Parallel Connection

This is a Parallel connected SPD – not series connected. As outlined above, an SPD ‘drains off’ excessive voltage from an electrical system. Because of parallel connection, installation of the SPD near the equipment to be protected is satisfactory. This effect is similar to flushing any toilet in a house; pressure in the shower goes down. In an electrical system, a parallel connected SPD will remove excessive voltage off the entire system (assuming reasonable proximity).

Tip: It is critically important that wiring leads be configured as short & straight as possible. Avoid long leads. Avoid sharp bends. Route SPD conductors in the same conduit. Leads do not have to be sized for the entire load – this SPD is parallel connected, not series connected. As a generalization, 6 AWG works fine.

Precautionary Statement Regarding SPDs on Ungrounded Systems

Caution – Ungrounded systems are inherently unstable and can product excessively high line-to-ground voltages during certain fault conditions. During these fault conditions, any electrical equipment including an SPD, may be subjected to voltages which exceed their designed ratings. This information is being provided to the user so that an informed decision can be made before installing any electrical equipment on an ungrounded power system.

Unpacking & Preliminary Inspection

Inspect the entire shipping container for damage or signs of mishandling. Remove the packing materials and further inspect the unit for any obvious shipping damages.

If any damage was found and is a result of shipping or handling, immediately file a claim with the shipping company and forward a copy to APT.

Storage Environment

This SPD should be stored in a clean, dry environment. Storage temperature range is -40°C (-40°F) to +60°C (+140°F). Avoid exposure to high condensation.

PRE-INSTALLATION & PLANNING

Operating Environment

The standard unit is in a Type 1 enclosure. Other enclosure types are available as options. Before installing, ensure that your enclosure type and application are appropriate per NEMA 250 with regard to moisture, dirt, excessive dust, flammable materials or atmospheres, corrosive vapors, etc.

This SPD is designed in an ambient temperature range of -40°C (-40°F) to +60°C (+140°F) with a relative humidity of 0% to 95% (non-condensing). Excessive temperature may inadvertently operate internal thermal overtemperature protectors.

Audible Noise

SPD background noise is negligible or non-existent, and does not restrict the location of installation.

Mounting, Dimensions, and Weight

This SPD is designed to be wall mounted. The standard enclosure is: 12" x 12" x 6" (L/W/D), and the weight is 25 lbs. The XTE Series is designed for internal mounting in the electrical distribution equipment. Standard backplane size is: 10.75" x 10.88" x 4.5", and the weight is 15 lbs.

Service Clearance

Service clearance is needed at the front of the TE Series unit only, 36 inches minimum is the required distance for clearance pursuant to the NEC®.

Maximizing SPD Performance

SPD's must be located as close to the circuit as possible to minimize parasitic losses. Surges are high current, high frequency events that cause substantial voltage drops across conductors. This hurts SPD performance. Use the shortest & straightest possible leads. Pre-Plan installations and ensure that nearest breaker positions are used. If new construction, adjust breaker locations as appropriate.

Tip: Voltage drops for normal 120V or 277V lines might be 2-3V per hundred feet. In surge applications, voltage drops might be 100-150V per foot. These voltage drops add to clamping voltage, thus hurting performance. Make every effort to keep leads short and straight.

As distribution gear becomes larger, shorter leads are more difficult to accomplish. When longer leads are unavoidable, gently twist leads together (one to two twists per foot), or tie-wrap leads together.

Tip: surges create magnetic fields per the 'right-hand rule'. When current goes in direction of thumb, magnetic field is in direction of curl of fingers. As surge

current goes to SPD, fields are created in one direction. When the SPD sends those currents to neutral and/or ground, current goes in the opposite direction. If 'coming & going' are on the same axis, the magnetic fields can be cancelled, thus avoiding performance decrease. Gentle twists, bundling & tie-wraps accomplish this.

Cascade Surge Protection

For optimum surge protection, cascade or staged surge suppression should be implemented at the service entrance and downstream locations as appropriate. Known or expected surge sources, as well as sensitive loads, should also have localized surge suppression. For interconnected electronic loads (data cabling), SPDs should also be utilized to protect the devices on either end of the interconnecting data cables.

Overcurrent Protection

SPDs draw very little current under normal conditions and conduct for a brief duration upon encountering a transient surge current. This SPD contain internal overcurrent and overtemperature protection to protect against abnormal voltage conditions.

Supplemental overcurrent protection is not required to protect this SPD. However, connecting conductors require protection in Type 2 or 4 applications. Follow applicable codes.

Circuit Breaker and Disconnect Switch

This XGA family SPD is tested and qualified as a Type 2 SPD per UL 1449 Third Edition and 2008 NEC®. This SPD can be installed on the load side of the service overcurrent device per 2008 NEC® Article 285.

When connected on load side of main disconnect, we suggest connecting via a 60A circuit breaker. The circuit breaker is the intended disconnect switch and provides short circuit protection to the connecting conductors. The XGA Series has internal overload protection elements within the product. A breaker or disconnect is not required for the SPD's overcurrent protection. XGA SPD's have demonstrated 200kA Short Circuit Current Ratings (SCCR). Confer to label on unit.

Wire Size and Installation Torque

This is a parallel-connected SPD; it is not series-connected. The size of the SPD wiring is independent of the ampere rating of the protected circuit. Recommended wire is 6 AWG for phase, neutral and ground connections. Torque connections to 18 inch-pounds. Conductor length should be as short as possible.

If other wire sizes are used, we recommend that all conductors be the same gauge. Note that larger conductor might appear to be beneficial; however, it tends to have the same inductance as smaller conductor and is more difficult to work with.

Terminals accept 14 - 2 AWG conductor with 6 AWG being preferred. Coordinate conductor size and overcurrent protection per applicable codes.

Special Enclosure Considerations

Removing and Reconnecting the Ribbon Cables

The ribbon cables are marked with matching phase connections. If any of the cables are removed, reconnect the cables as marked.

NEMA Type 4X Enclosure

On rare occasions in high temperature climates, XGA's inside clear-cover polycarbonate enclosures have experienced internal temperatures exceeding 200°F. This inadvertently operates the overtemperature safety disconnects inside the SPD. We recommend positioning the unit so that the clear front avoids direct summer sunlight by shading or not facing west.

The NEMA Type 4X enclosure is shipped with its mounting brackets and installation screws packaged inside it. Use the enclosed 1/4-20 x 1/2 in. slotted screws to secure the brackets to the enclosure before installing the XGA SPD device. Torque these screws to a maximum of 50lb-in. (6N·m). When installing the cover for the NEMA Type 4X enclosure, torque the cover screws to a maximum of 25lbs-in. (3 N·m).

Flush Mount Option

Remove the display panel and barrier before making any electrical connections. Replace the barrier and display panel before energizing the device.

The XGA is approximately 5.25 in. (133 mm) deep. The XGA will not flush mount unless there is at least 5.25 in. (133 mm) of clearance. The XGA is not designed to flush mount on a typical 2 x 4 stud wall.

Follow steps 1-5 to flush mount the XGA.

1. Before removing the trim, disconnect the ribbon cables and ground wire from the modules.
2. Mount the device as close as possible to the panel being protected. Create a wall opening slightly larger than 12 in. high by 12 in. wide (305 mm high by 305 mm wide). See figure 2.
3. Install a backing plate inside the wall cavity 5.25 in. (133 mm) from the wall face such that the XGA will be supported from its back. See figure 3. Note the mounting holes on the back of the enclosure. Also note that the XGA weighs 25 lb (12 kg) maximum.
4. Configure the electrical conductor and conduit connections consistent with the wiring instructions beginning on page 7.
5. Carefully reattach the ribbon cables and the ground wire to the modules and reattach the display panel/cover before energizing and testing the device.

Terminals

Terminals will accept 14 - 2 AWG conductor and are provided for line (phase), neutral (if used), and equipment safety ground connections. 8 AWG is the minimum recommended wire size because UL testing and evaluation was performed using 8 AWG.

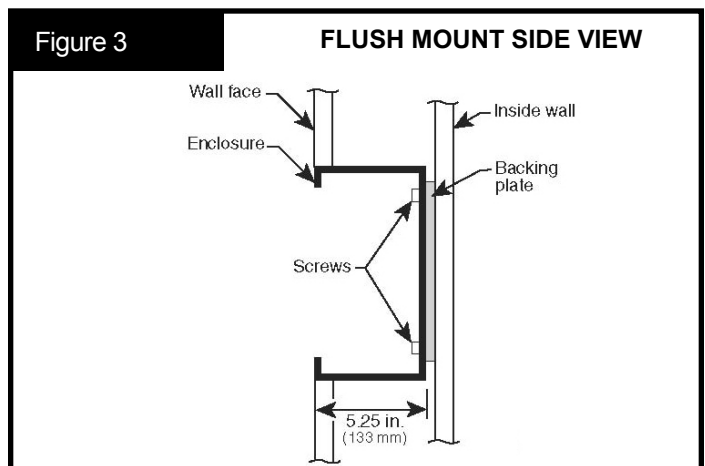
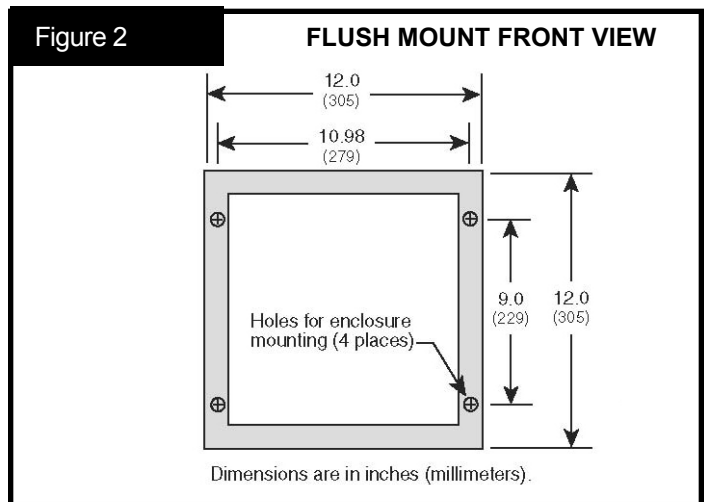

Shortest Leads Possible

- Leads must be as short and straight as possible - See **NEC® Art. 285.12**
- Pretend wire is \$1000 per foot coming out of your pocket
- No long leads
- No sharp bends
- No wire nuts
- How short is short enough? As short as you can make it
- How long is too long? If anyone else can make it shorter

Configuration Management & Part Numbering System

TE series correct installation orientation is such that the door will hinge from the left. (XTE has no enclosure or door and is typically factory installed)

Locate the unit's printed identification nameplate on the inside of the hinged door, although options may dictate placing it in a conspicuous location elsewhere. The model number can be decoded as follows:

- TE identifies an external mount Transient Eliminator® followed by a slash (/). XTE identifies an enclosure - less model followed by a slash (/).
- A one or two digit number will precede the letters XGA. This number indicates the voltage and wiring configuration of the device. Refer to page 5 to identify and confirm correct application.
- XGA identifies the XGA Series, followed by a slash (/)
- Following the second slash may be a /240. These numbers identify optional per phase Surge Current Ratings. (Please note: The Standard 160kA Rating does not have a /160 identifier.)

Options are identified after the Surge Current Rating and are individually separated by a slash. (Options are detailed later in this manual.)

Example: TE/2XGA/240/DC/RM/4X identifies a Transient Eliminator® XGA Series SPD (external mount), 208Y/120V, 3 Phase, 4 Wire (plus Ground), with a 240kA per phase Surge Current Rating with: Dry Contact, Remote Monitor, and a NEMA 4X Enclosure.

Voltage Rating

Before installing SPD, verify that it has the same voltage rating as the power distribution system. Compare the SPD's nameplate voltage or model number and ensure that SPD configuration matches the intended power source. See Table 1.

The specifier or the user of the device should be familiar with the configuration and arrangement of the power distribution system in which any SPD is to be installed. The system configuration of any power distribution system is based strictly on how the secondary windings of the transformer supplying the service entrance main or load are configured. This includes whether or not the transformer windings are referenced to earth via a grounding conductor. The system configuration is not based on how any specific load or equipment is connected to a particular power distribution system.

480V System Example: SPDs should be installed per the electrical system, not per a load or motor's wiring connection. For example, a 480V three phase motor might appear to be connected as a 480V Delta. In actuality, the serving distribution system might be a 480Y/277V grounded Wye, with or without a neutral pulled to the motor or MCC. The system is still a 480Y/277V Wye, even though the load is connected as a Delta. A grounded Wye has a defined reference to ground (i.e., neutral is bonded to ground). Some Delta systems are ungrounded, which have no reference to ground and are known

to become unstable in certain situations. Such instability can cause line to ground voltage fluctuations that may prematurely fail SPDs. For this reason, the NEC® Article 285 has placed SPD restrictions on ungrounded systems. As generalizations, SPDs for ungrounded systems can be installed on grounded systems with a clamping performance penalty. However, SPDs for grounded systems installed on ungrounded systems are almost certainly destined for premature failure. Call APT Tech Support at (800) 237-4567 for further information.

TABLE 1: VOLTAGE RATING AND SERVICE TYPE	
TE & XTE / 1XGA	120/240 Single Phase, 3 Wire, "Grounded"
TE & XTE / 11XGA	120 Single Phase, 2 Wire, "Grounded"
TE & XTE / 12XGA	240 Single Phase, 2 Wire, "Grounded"
TE & XTE / 2XGA	120/208 Three Phase, 4 Wire, "Grounded", WYE
TE & XTE / 3XGA	120/240 Three Phase, 4 Wire, "High-Leg", DELTA
TE & XTE / 4XGA	277/480 Three Phase, 4 Wire, "Grounded", WYE
TE & XTE / 5XGA	480 Three Phase, 3 Wire, DELTA
TE & XTE / 51XGA	480 Three Phase, "Corner Grounded", DELTA
TE & XTE / 6XGA	240 Three Phase, 3 Wire, DELTA
TE & XTE / 61XGA	240 Three Phase, "Corner Grounded", DELTA
TE & XTE / 7XGA	220/380 Three Phase, 4 Wire, "Grounded", WYE
TE & XTE / 8XGA	347/600 Three Phase, 4 Wire, "Grounded", WYE
TE & XTE / 9XGA	600 Three Phase, 3 Wire, DELTA
TE & XTE / 91XGA	600 Three Phase, "Corner Grounded" DELTA

System Grounding

An equipment grounding conductor must be used on all electrical circuits connected to the SPD.

For the best performance, use a single point ground system where the service entrance grounding electrode system is connected to and bonded to all other available electrodes, building steel, metal water pipes, driven rods, etc. (for reference see: IEEE Std 142-2007).

For sensitive electronics and computer systems, we recommend that the ground impedance measurement be as low as possible. When metallic raceway is used as an additional grounding conductor, an insulated grounding conductor should be run inside the raceway and sized per the NEC®. Adequate electrical continuity must be maintained at all raceway connections. Do not use isolating bushings to interrupt a metallic raceway run.

A separate isolated ground for the SPD is NOT recommended. Proper equipment connections to grounding system and ground grid continuity should be verified via inspections and testing on a regular basis as part of a comprehensive electrical maintenance program.

On 4-Wire Power Systems, neutral to ground bonding (Main Bonding Jumper) must be installed per the NEC®. Failure to do so WILL damage SPDs.

TABLE 2: MODEL NUMBER DECODER

Do not create model numbers from this chart as all features are not available on all models

Model Family	Option Suffixes (Separated by slashes -)
<p>TE = Transient Eliminator, Listed Type 2 SPD in NEMA 1 enclosure</p> <p>XTE = Transient Eliminator, Recognized Type 4 SPD on backplane for installation within gear in Type 2 installation (display on 6' cable)</p>	<p>/240 = 240kA Option</p> <p>/090 = 090kA SAD option (120/240V & 208Y/120)</p> <p>/130 = 130kA SAD option (120/240V & 208Y/120)</p> <p>/170 = 170kA SAD option (120/240V & 208Y/120)</p> <p>/DC = Dry Contacts</p> <p style="padding-left: 20px;">Two sets Form C (24V, 1A)</p> <p>/SC = Surge Counter, six digit LCD</p> <p>/2S = Dual Surge Counter</p> <p>/12 = NEMA 12 Enclosure (12" x 12" x 6")</p> <p>/3R = NEMA 3R Enclosure (12" x 12" x 6" - display inside door)</p> <p>/04 = NEMA 4 Enclosure (12" x 12" x 6" - display inside door)</p> <p>/FM = Flush Mount enclosure, NEMA 1 only (wall cavity size: 12"x12"x6" deep)</p> <p>/4X = NEMA 4X Non-metallic enclosure (polycarbonate, 14"x12"x6" - display inside door)</p> <p>/4S = NEMA 4S Stainless Steel enclosure (12"x12"x6" - display inside door)</p> <p>/TN = NEMA 1/12/3R/4 Enclosure (10" x 10" x 6")</p> <p>(Note: Enclosure-less version for OEM uses XTE prefix)</p>
<p>Voltage Code for Electrical System</p> <p>Common North American Systems:</p> <p>01 = 240/120V Split Phase - 1Ø 3W+Grnd (Fig 1)</p> <p>02 = 208Y/120V Wye - 3Ø 4W+Grnd (Fig 2)</p> <p>03 = 240/120V High Leg Delta (B High) (Fig 3)</p> <p>04 = 480Y/277V Wye - 3Ø 4W+Grnd (Fig 2)</p> <p>05 = 480V Delta - 3Ø 3W+Grnd (Fig 4) & HRG Wye</p> <p>08 = 600Y/347V Wye - 3Ø 4W+Grnd (Fig 2)</p> <p>Other Available Systems - Confirmation encouraged:</p> <p>15 = 254/127V Split Phase - 1Ø 3W+Grnd (Fig 1)</p> <p>18 = 480/240V Split Phase, or Two legs of Wye (Call)</p> <p>21 = 220Y/127V Wye - 3Ø 4W+Grnd (Fig 2)</p> <p>41 = 520Y/300V Wye - 3Ø 4W+Grnd (Fig 2)</p> <p>42 = 415Y/240V Wye - 3Ø 4W+Grnd (Fig 2)</p> <p>43 = 400Y/230V Wye - 3Ø 4W+Grnd (Fig 2)</p> <p>44 = 440Y/250V Wye - 3Ø 4W+Grnd (Fig 2)</p> <p>51 = 480V B Corner Grnd Delta, 3Ø 3W+Grnd (Fig 6)</p> <p>06 = 240V Delta - 3Ø 3W+Grnd (Fig 4)</p> <p>61 = 240V B Corner Grnd Delta, 3Ø 3W+Grnd (Fig 6)</p> <p>07 = 380Y/220V Wye - 3Ø 4W+Grnd (Fig 2)</p> <p>09 = 600V Delta - 3Ø 3W+Grnd (Fig 4) & HRG Wye</p> <p>91 = 600V B Corner Grnd Delta, 3Ø 3W+Grnd (Fig 6)</p>	<p>Available Accessory (order separately):</p> <p>RM = Remote Monitor</p>

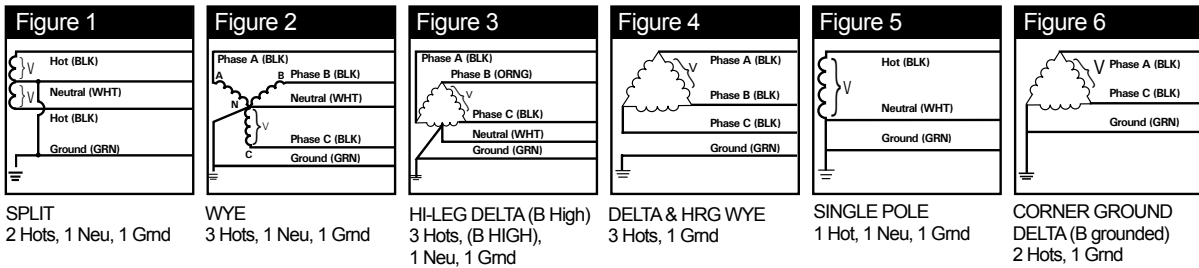

UL 1283 required language concerning the installation of EMI Filters

a) An insulated grounding conductor that is identical in size and insulation material and thickness to the grounded and ungrounded circuit supply conductors, except that it is green with or without one or more yellow stripes, is to be installed as part of the circuit that supplies the filter. Reference should be made to Table 250-122 of the National Electrical Code regarding the appropriate size of the grounding conductor.

b) The grounding conductor mentioned in item a is to be grounded to earth at the service equipment or other acceptable building earth ground such as the building frame in the case of a high-rise steel-frame structure.

c) Any attachment-plug receptacles in the vicinity of the filter are to be of a grounding type, and the grounding conductors serving these receptacles are to be connected to earth ground at the service equipment or other acceptable building earth ground such as the building frame in the case of a high-rise steel-frame structure.

d) Pressure terminal or pressure splicing connectors and soldering lugs used in the installation of the filter shall be identified as being suitable for the material of the conductors. Conductors of dissimilar metals shall not be intermixed in a terminal or splicing connector where physical contact occurs between dissimilar conductors unless the device is identified for the purpose and conditions of use.

Figure 4

SPD DIMENSIONS
NEMA TYPE 1, 4, AND 4X STAINLESS STEEL

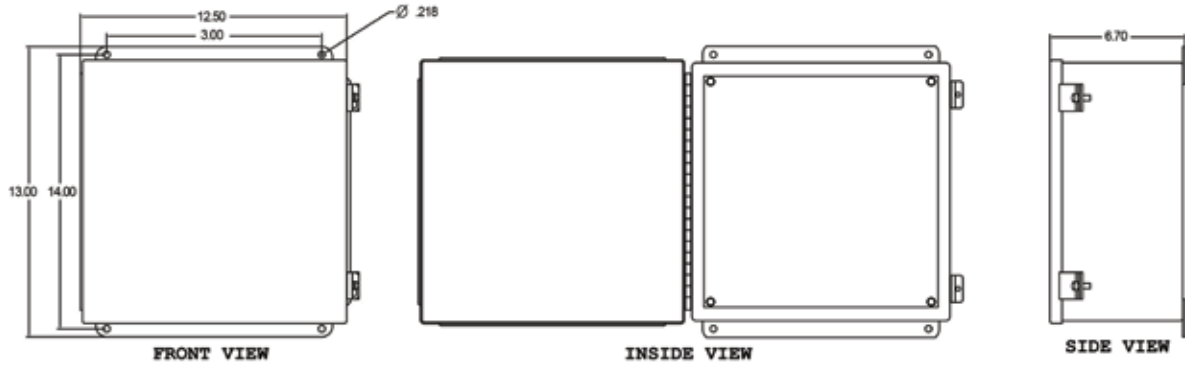

Figure 5

SPD DIMENSIONS
NEMA TYPE 3R

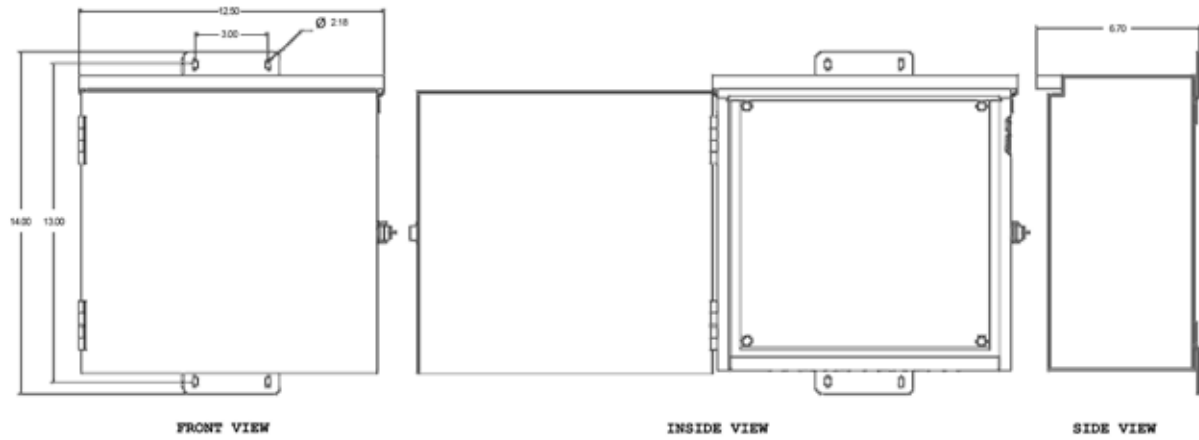
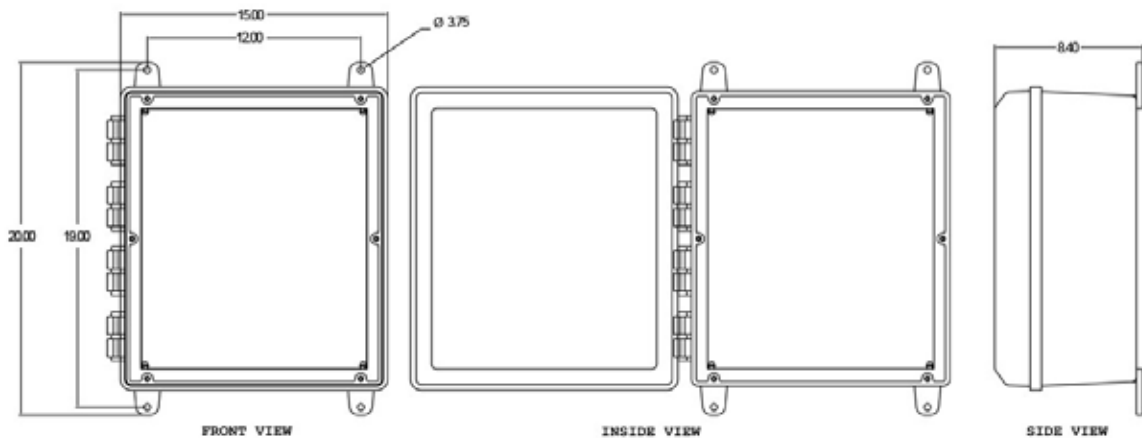

Figure 6

SPD DIMENSIONS
NEMA TYPE 4X PLASTIC



INSTALLATION

Common Problems to Avoid

- Confirm System voltage to SPD voltage (120V SPD will fail instantly on 240V, 277V, etc.)
- Locate SPD close so leads are short & straight as possible (or will seriously hurt performance)
- Make sure N-G or XO bonding meets NEC® (or will prematurely fail SPD)
- Energize SPD AFTER system is stabilized & checked (inadvertent system problem may fail SPD)
- SPDs are regulated by NEC® Article 285 and UL 1449
- Never Hi-Pot test any SPD (will prematurely fail SPD)

Pre-Plan your installation.

You will need to accomplish the following:

- Meet all National and Local codes (NEC® Article 285 addresses SPDs)
 - Mount SPD as close to panel or equipment as possible to keep leads short
 - Ensure leads are as short and straight as possible, including neutral and ground. Consider a breaker position that is closest to the SPD and the panel's neutral & ground
 - Suggested breaker & conductor size is 60A-30A with 6 AWG (60A preferred)
 - Make sure system is grounded per NEC® and clear of faults before energizing SPD.
1. Use a voltmeter to check all voltages to ensure correct SPD
 2. If SPD has Dry Contact, Remote Monitoring or Remote Display, pre-plan their installation
 3. Remove power for panel. Confirm panel is deenergized.
 4. Identify breaker location and SPD location.
 5. Make sure leads are short! Reducing inches matters! Pretend that connector leads cost you \$1000 per foot!
 6. Remove an appropriately sized knockout from panel. Create an appropriately sized hole in the SPD enclosure.
 7. Mount SPD
 8. Connect conductors as appropriate – short and straight as possible (Note that Hi-Legs are Phase B)
 9. Label or mark conductors as appropriate (neutral: white, ground: green, energized: black, hi-leg: orange)
 10. Make sure system is bonded per NEC® and is clear of hazards or faults before energizing (N-G bonding not per NEC® will fail SPDs: #1 cause of SPD failures)
 11. Energize and confirm proper operation of indicators and/or options.

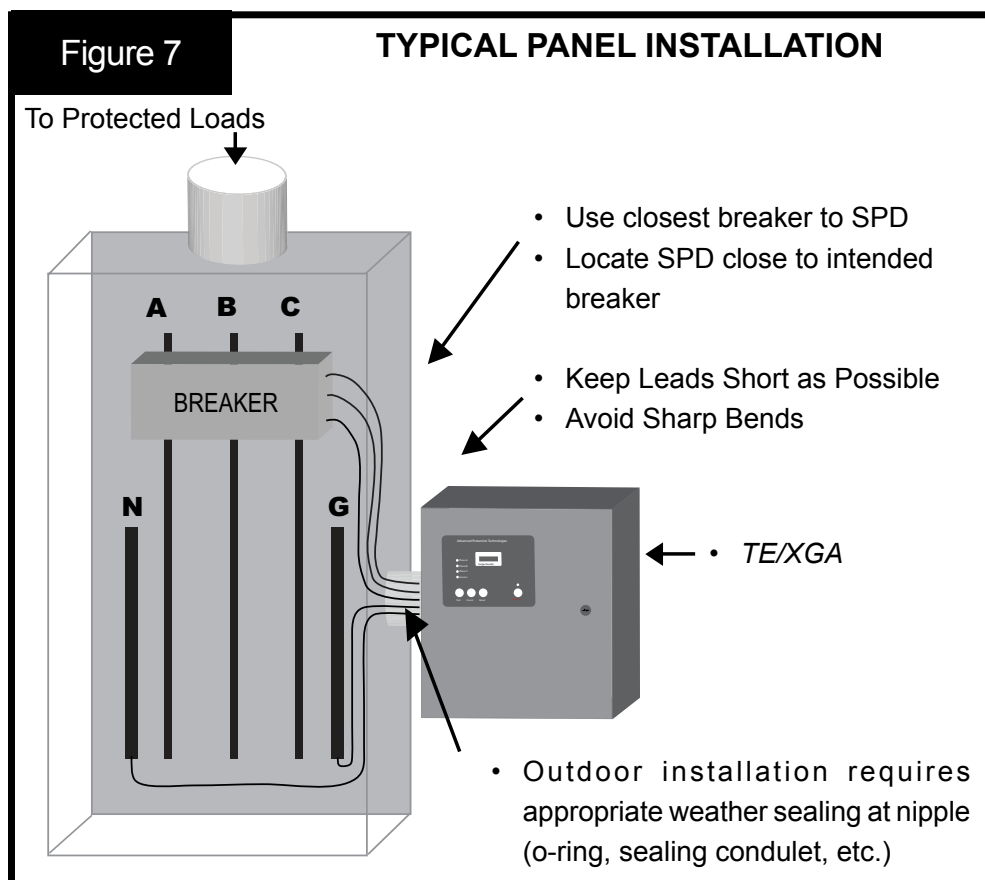

Electrical Connection Diagrams

Figure 8

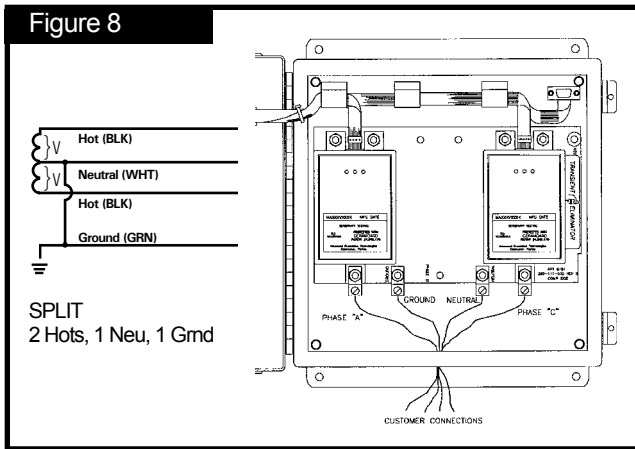

Figure 9

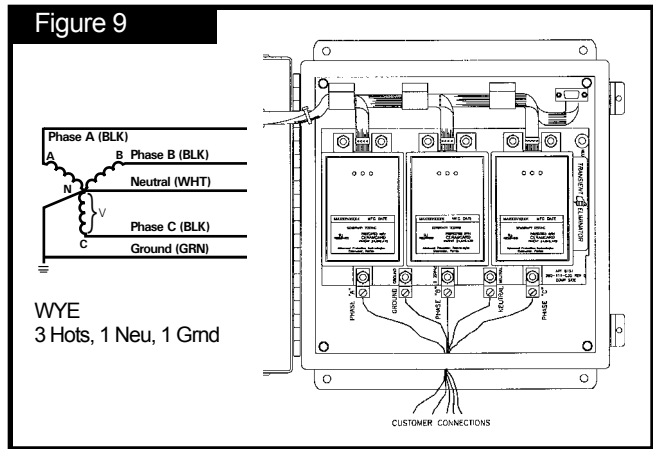

Figure 10

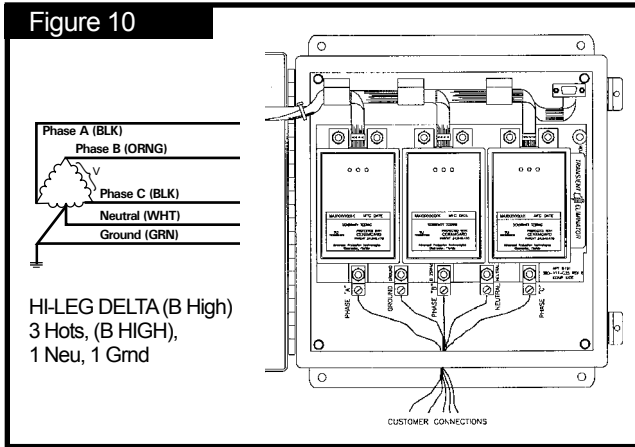

Figure 11

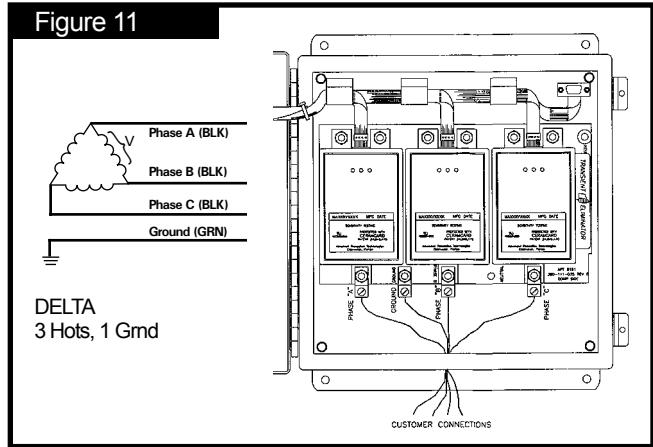

Figure 12

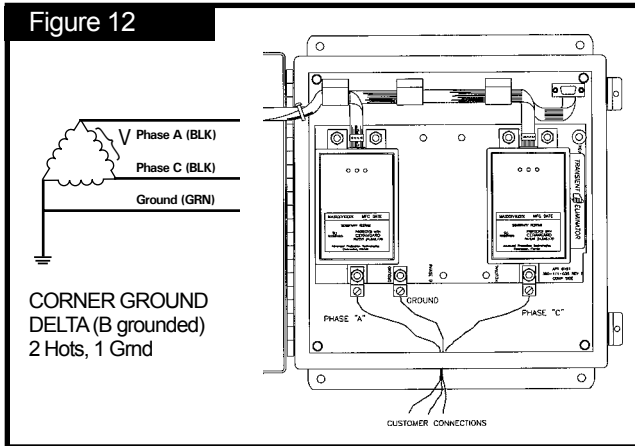
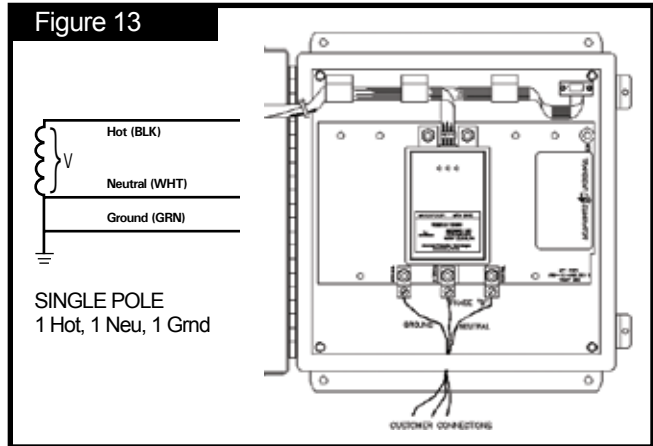
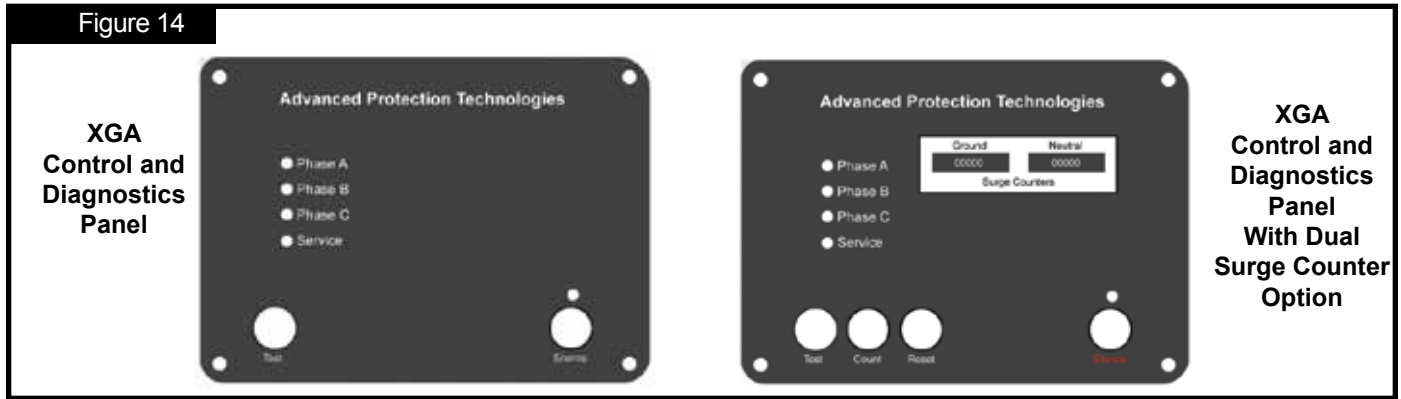

Figure 13



OPERATION

Figure 14



Control and Diagnostic Panel

All indicators and controls are located on the front diagnostic panel. Green LEDs indicate correct operation.

Phase A, B & C: Tri-Color LED status indicators – one per phase

Green – Full Protection

Amber – Partial Protection

Red – No Protection

Service LED (red): LED illuminates in the event of problem. This indicator is logic-connected to the Phase LEDs. Should a Phase LED go out, the red Service LED will illuminate and the Audible Alarm will sound.

Test: Tests red Service LED and Audible Alarm regardless of Alarm Silence status; does not cycle optional dry contacts

Alarm Silence: Turns Audible Alarm off (Audible Alarm is deactivated when LED is illuminated)

Surge Counter Count: (if equipped) Increments optional surge counter by one (+1)

Surge Counter Reset: (if equipped) Resets optional surge counter to zero (0)

If an inoperative condition were to occur, the built-in audible alarm will sound and the red Service LED will illuminate. This indicates that the unit needs evaluation by a qualified electrician or technician. Until a qualified person evaluates the unit, press Alarm Silence to silence the alarm. (The LED above Alarm Silence illuminates when the alarm is deactivated. Normal operation occurs with the Alarm Silence LED extinguished.) The red Service LED will remain illuminated even though the Audible Alarm has been silenced. Test tests the red.

Service LED and the Audible Alarm

Diagnostics will indicate a failure upon loss of voltage or significant drop in voltage. Be aware that ground faults on ungrounded or resistive ground systems will trigger a failure alarm on this SPD.

If LEDs are illuminated in a manner that suggests contradictory information, there may be an internal logic problem and the unit needs replaced. If none of the LEDs are illuminated, the unit may not be installed correctly. For troubleshooting assistance, please contact APT Technical Support at (800) 237-4567.

Surge Counter Options

The surge counter registers the number of transient overvoltages on all L-N and L-G modes since the counter was last reset. The counter is inductively coupled from each mode of protection. It increments upon significant current change in a short time period (large di/dt).

The surge counter includes *Test* and *Reset* buttons on the touchpad display. Pressing *Test* adds one count. Pressing *Reset* clears the counter's memory and sets the display to zero.

The counter option includes a SuperCap internal storage capacitor that provides backup power for up to four days in the event of a power outage. This eliminates the maintenance of battery backups. There is a 10-15 minute charging cycle before the counter(s) operate.

Single Counter – Totals the surges through the L-N and L-G

Dual Counters – Is used to distinguish between L-N and L-G surges. Two separate counters are used, with common *Reset* and *Test* tabs.

Supplemental LED indicators on Modules

Each module includes three LEDs per Figure 15. The center green LED indicates power is on. This green LED should be illuminated during normal operation.

When the upper left red LED is illuminated, the module's L-G protection is lost.

When the upper right red LED is illuminated, the module's L-N protection is lost.

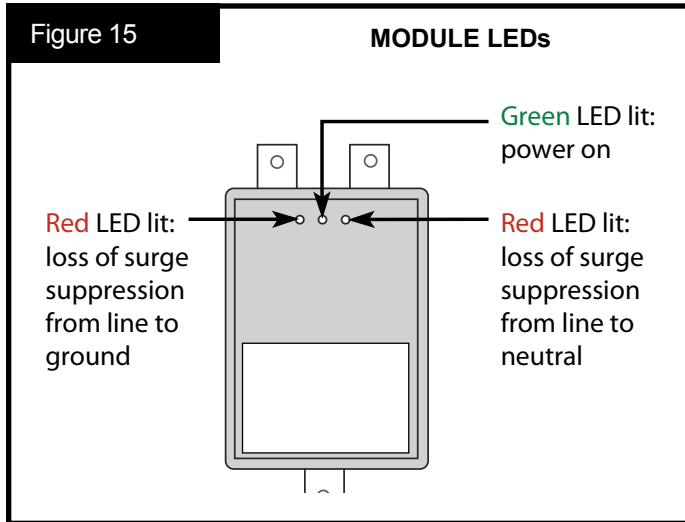

Dry Contact Option

The XGA Series is available with optional Dry Contacts which utilize a DB-9 connector. This feature provides two sets of normally open (N.O.) and normally closed (N.C.) contacts through the DB-9 connector. These relay contacts can be used for remote indication of the SPD's operating status. Examples could include a computer interface board, an emergency management system, etc. The relay contact pin arrangement is outlined in Table 2. (Please note the jumpered connections. Pins 7, 8 & 9 were used to drive an earlier version of the Remote Monitor option. Pins 7, 8 & 9 do not represent a third set of contacts. Pin pairs 4 & 7, 5 & 8, and 6 & 9, are connected via jumper internally. The combined current of each pin pair may not exceed 1 Ampere).

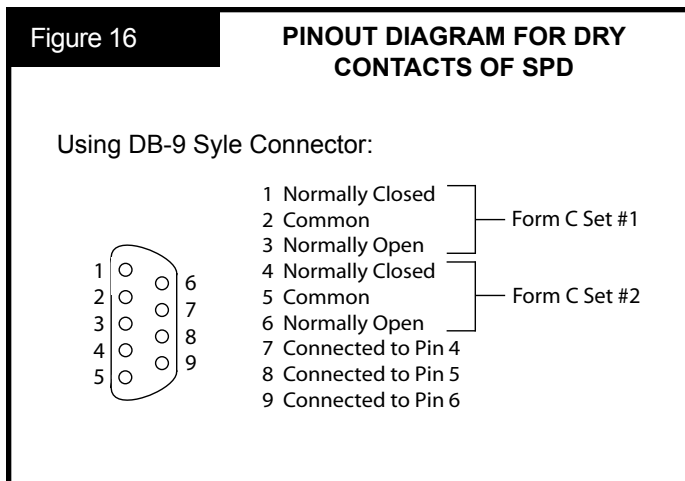

An optional Remote Monitor accessory is available that will provide visual and audible indication of an alarm condition. The Remote Monitor requires the Dry Contact's option as it collects information through the Dry Contact's DB-9 connection. Please note that the DB-9 connector is completely utilized by the optional remote monitoring accessory. If the Remote Monitor is used, there will be no means to interface with another device.

For custom applications using the Dry Contacts, please note the following information:

- The Dry Contacts are designed for low voltage or control signals only.
- Maximum switching current is 1 amp.
- Maximum switching voltage is 24 volts, DC or AC.

Higher energy application may require additional relay implementation outside the SPD. Damage to the SPD's relay caused by implementation with energy levels in excess of those discussed in this manual will not be covered by warranty. If you have design questions, please contact APT Technical Support at: 1.800.237.4567.

Remote Monitor Accessory Option

A Remote Monitor is available for remote annunciation. It requires a standalone 120V power source (wall plug transformer) and uses one set of Form C dry contacts. The Remote Monitor can be configured to monitor several APT SPDs simultaneously. Installation is detailed in a separate document. Contact factory as appropriate.

MAINTENANCE

SPDs require minimal maintenance. We recommend periodic inspection of diagnostic indicators to ensure proper operation. We also recommend keeping the SPD clean as appropriate.

Troubleshooting & Service

Please contact us for any service related issues. We want to take care of any problems.

Quality SPDs are designed and tested to withstand severe duty. However, there are various electrical anomalies that SPDs cannot protect against. These are generally Sustained Overvoltages also known as Temporary Overvoltages (TOVs). In this context, Sustained Overvoltages may be only a few cycles. Failed SPDs tend to be symptoms, not root causes. A failed SPD should be treated as a 'canary in the coalmine' suggesting further investigation as there may be a larger issue at play. Regardless of cause, SPDs attempt to protect their load until failure.

As noted above, the single largest 'killer' of SPDs is reference to ground issues. If the SPD shows problems on startup, there is reasonable chance of bonding/grounding/misapplication issue. This permanently damages the unit. If not corrected, it will happen again.

Tip: Visually confirm N-G bonding. Be aware that a voltmeter measuring N-G can be misleading. For example, N-G voltage could read 0V because neutral and ground are at the same potential purely by happenstance, not because they are bonded. Visually confirm bonding.

Tip: Experience indicates that regulation-challenged generators can cause Sustained Overvoltages, as well as ungrounded generators, and/or unusual load transfer systems.

Note: Prior to returning power or servicing the SPD, inspect the entire SPD for any other damaged components. Any damaged components should be replaced prior to returning the SPD to service.

Module Removal and Replacement

Disconnect power to the SPD. DISCHARGE INTERNAL CAPACITORS BY GROUNDING. Unplug the 10 pin connector from the XGA module. Using a 7/16" socket wrench, remove the bolts on both ends of the module, and pull the module out. Make note of the location and part number of each module removed, as this part number is not referenced anywhere else on the SPD. The module(s) should only be replaced with a new module bearing the same part number as the module(s) previously removed. Replace with a new module by reversing the procedure. Torque bolts to 65 inch-pounds, power up the SPD and verify the green module LED is lit and all alarms have been cleared.

Display/Diagnostic Board Removal and Replacement

Disconnect power to the SPD. Remove the nuts from the switches that secure the board to the panel, then remove the board. Remove the connectors one at a time from the existing board and insert them into the appropriate connector on the replacement board. Install the replacement board into the panel and install the nuts onto the switches and tighten securely.

Note that a sealing gasket between the display and the enclosure is a key component ensuring weather resistance. Replace the gasket whenever the display is removed.

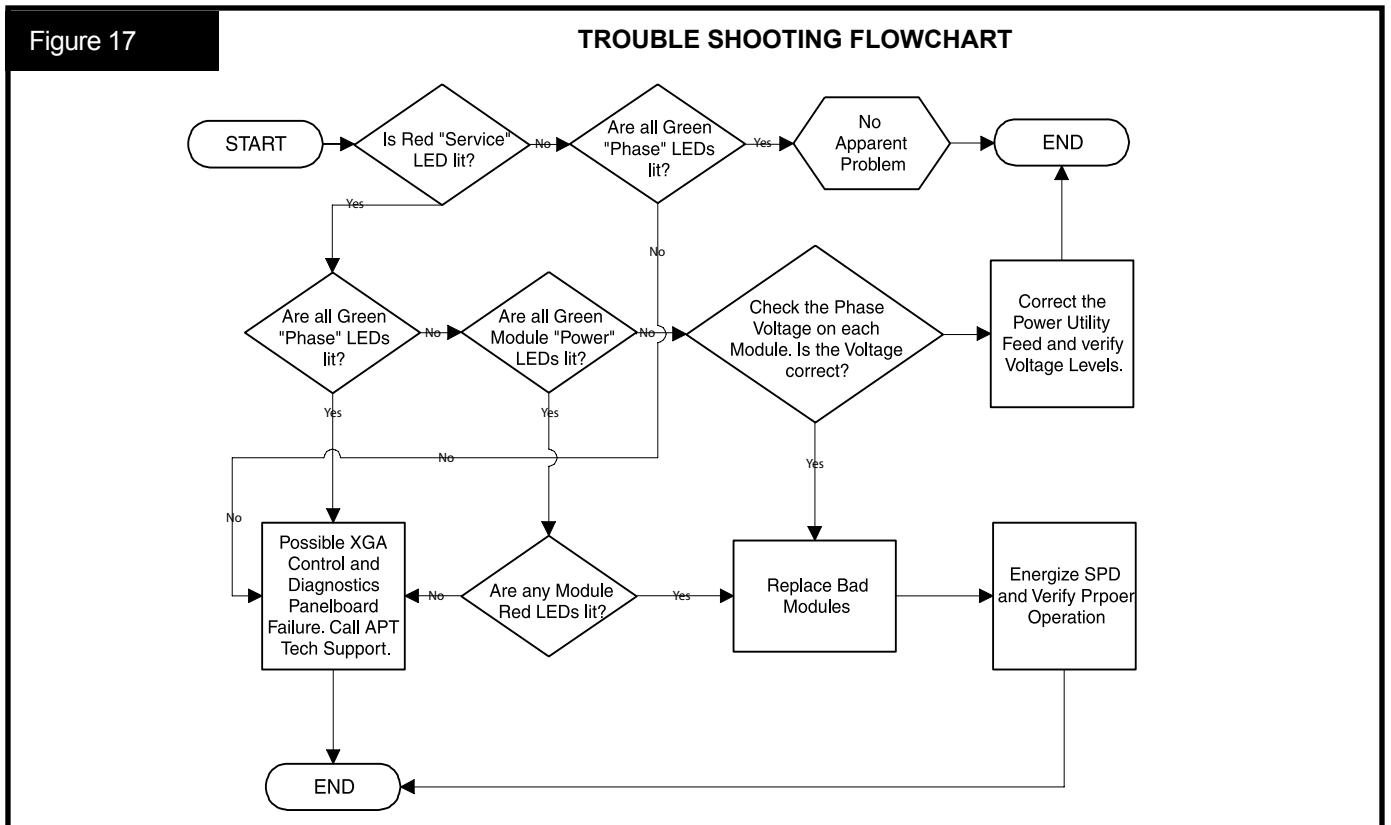

Preventive Maintenance (Inspection and Cleaning)

Inspection of the SPD should be performed periodically to maintain reliable system performance and continued transient voltage surge protection. While it is difficult to establish a preventive maintenance schedule because conditions vary from location to location, inspections for inoperative modules and other signs of trouble utilizing the built-in diagnostics should be performed on a routine basis (weekly or monthly).

TABLE 3: REPLACEMENT PARTS		
ORDER#	DESCRIPTION	USED IN
MA120V090K	Module	120 VAC with LED 90kA
MA220V090K	Module	220 VAC with LED 90kA
MA277V090K	Module	277 VAC with LED 90kA
MA120V130K	Module	120 VAC with LED 130kA
MA220V130K	Module	220 VAC with LED 130kA
MA277V130K	Module	277 VAC with LED 130kA
MA120V160K	Module	120 VAC with LED 160kA
MA220V160K	Module	220 VAC with LED 160kA
MA240V160K	Module	240 VAC with LED 160kA
MA277V160K	Module	277 VAC with LED 160kA
MA347V160K	Module	347 VAC with LED 160kA
MA480V160K	Module	480 VAC with LED 160kA
MA600V160K	Module	600 VAC with LED 160kA
MA120V170K	Module	120 VAC with LED 170kA
MA220V170K	Module	220 VAC with LED 170kA
MA277V170K	Module	277 VAC with LED 170kA
MA120V240K	Module	120 VAC with LED 240kA
MA220V240K	Module	220 VAC with LED 240kA
MA220V240K	Module	240 VAC with LED 240kA
MA277V240K	Module	277 VAC with LED 240kA
MA347V240K	Module	347 VAC with LED 240kA
MA480V240K	Module	480 VAC with LED 240kA
MA600V240K	Module	600 VAC with LED 240kA

*For Ordering Front Display Panel, contact
APT for part number*

Corrective Maintenance (Repair)

APT's Surge Protective Devices are designed for years of reliable, trouble-free operation. Unfortunately, even the most reliable equipment can become inoperative. On-line diagnostics are an integral part of the SPD and will aid in isolating which of the protection module(s) have become inoperative. To keep the SPD operating at peak performance, replacement of any inoperative module(s) should be performed according to module removal and replacement instructions at the earliest service opportunity.

Troubleshooting procedures should be used to isolate other problems not associated with inoperative module(s). See Figure 17, Troubleshooting Flow Chart on page 10 for assistance. Be sure to replace components with identically rated parts to continue proper operation and safety. Table 3 lists typical replacement parts.

Limited Warranty

Advanced Protection Technologies, Inc. warrants its AC panel protection products against defective workmanship and materials for 10 years (Optional warranty available) from the date of original purchase. The unit must have been installed by a qualified and licensed electrician in order to qualify for Warranty coverage.

Liability is limited to the replacement of the defective product. A Return Authorization (RA #) number must be given by the company prior to the return of any product. Returned products must be sent to the factory with the transportation charges prepaid. In addition, the company also warrants unlimited replacement of modular and component parts within the warranty periods previously described.

APT specifically disclaims all other warranties, expressed or implied. Additionally, the company will not be responsible for incidental or consequential damages resulting from any defect in any product or component thereof.

CONTACT US

Advanced Protection Technologies
14550 58th St. N.
Clearwater, FL 33760

(800) 237-4567
(727) 535-6339
Fax (727) 539-8955

www.aptspd.com

Any returns need a Return Authorization number.

14550 58th Street North ▪ Clearwater, Florida 33760

UL is a registered trademark of Underwriters Laboratories, NEC® and National Electrical Code are registered trademarks of National Fire Protection Association, C62.41.1-2002, C62.41.2-2002, C62.45-2002, C62.72-2007 are registered trademarks of IEEE.



ADVANCED PROTECTION TECHNOLOGIES INC.

“Professionals Serving Professionals”



Advanced Protection Technologies

14550 58th Street North ▪ Clearwater, Florida 33760
(800) 237-4567 ▪ (727) 535-6339 ▪ Fax (727) 539-8955
www.aptvss.com ▪ info@aptvss.com ▪ www.aptspd.com

European Authorized Representative:
Obelis S.A.
Boulevard Général Wahis, 53
B-1030 Brussels
Belgium
Tel.: +32.2.732.59.54 ▪ Fax: +32.2.732.60.02
Email: mail@obelis.net

UL is a registered trademark of Underwriters Laboratories, NEC and National Electrical Code are registered trademarks of National Fire Protection Association,
C62.41.1-2002, C62.41.2-2002, C62.45-2002, C62.72-2007 are registered trademarks of IEEE.